

MIA 10



- 1** Mid-woofer
 - ▶ 5" in fiber glass

- 2** Soft dome tweeter
 - ▶ with thermal dissipator

- 3** Dark ash / Teak color

- 4** Terminals

- 5** Front port



• THE OPINION OF THE LAB

The MIA 10 centre speaker has been designed to complete the DISCOVERY RANGE.

It offers excellent audio consistency thanks to its dynamic qualities of linearity and timbre.

The MIA 10 has been designed to produce a perfect homogeneity with the other speakers of the range and an excellent 3D image stability.

Our recommendations :

- configuration : SMALL (to cut the frequencies under 80 Hz, and increase the power handling)
- Position : just under the TV/screen, exactly at the middle

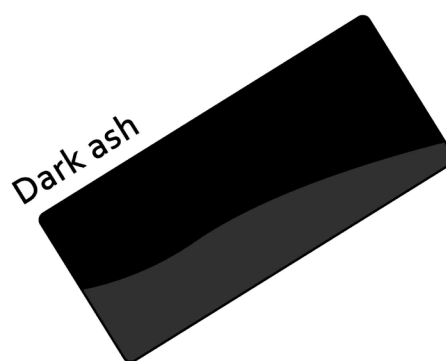
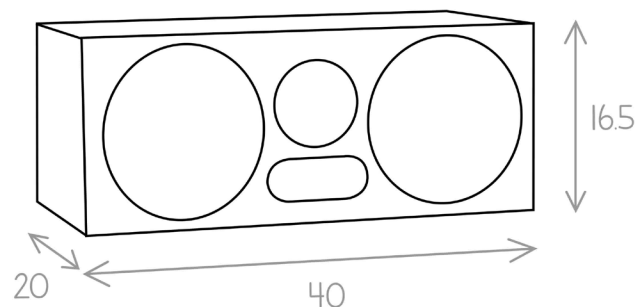

• CHARACTERISTICS MIA 10

Bass reflex	yes
Nom. power	80 W
Max. power	110 W
Number of ways	2
Number of drivers	2
Sensitivity	90 dB
Frequency range	55 -20000 Hz
Tweeter	25mm soft dome
Midrange	2 x 13 cm fiber glass
Woofers	-
Weight (kg)	4.7
Impedance	4 mini
Frequencies cut	300 / 3000 Hz